

SAACKE

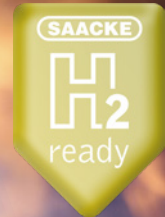

ROTONOX THE NEW ROTARY CUP ATOMIZER FOR PREMIUM EFFICIENCY.

- ✓ For all liquid and gaseous standard and special fuels
- ✓ Complies with European BAT specifications
- ✓ Outstanding durability

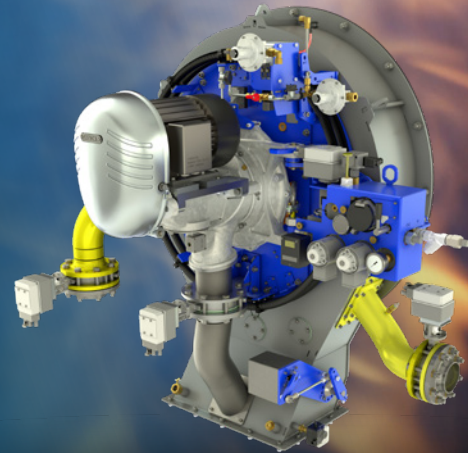

BURNER OVERVIEW.



Burner	SSB	TEMINOX	ATONOX
Burner capacity	1.5–90 MW	3–28 MW	7–100 MW
Fuels	Natural gas, liquid gas, hydrogen, light fuel oil, heavy fuel oil, synthetic fuels, special fuels (biogases, bio-oils, dust, lean gases, etc.)	Natural gas, liquid gas, hydrogen, light fuel oil, synthetic fuels, special fuels (biogases, bio-oils, etc.)	Natural gas, liquid gas, hydrogen, light fuel oil, synthetic fuels, special fuels (biogases, bio-oils, etc.)
Areas of application	New construction and modernization of industrial plants: Shell boilers, water-tube boilers, thermal fluid heaters, thermal processing plants, hot gas generators and combustion chambers, other thermal processing and drying plants, ignition and support firing	New construction and modernization of industrial plants: Shell boilers, water-tube boilers, thermal fluid heaters, thermal processing plants	New construction and modernization of industrial plants: Water-tube boilers, thermal fluid heaters, thermal processing plants

Diagram



ROTONOX

1–45.3 MW

Natural gas, liquid gas, hydrogen, light fuel oil, heavy fuel oil, synthetic fuels, special fuels (biogases, bio-oils, animal fats, special gases, special oils, other alternative liquid and gaseous fuels)

New construction and modernization of industrial plants: Shell boilers, water-tube boilers, thermal fluid heaters, thermal processing plants, hot gas generators, and combustion chambers

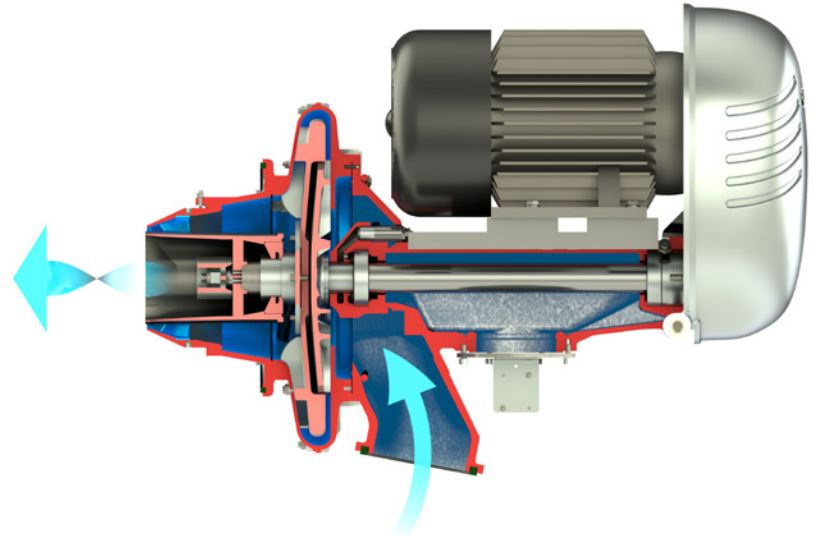

BENEFITS OF THE BURNER SYSTEM.

The **SAACKE ROTONOX** burns a wide range of gaseous and highly viscous liquid substances extremely cost-effectively and with fewer pollutants. The rotary cup atomizer technology offers you perfect combustion behavior with maximum efficiency, variability, and reliability.

- ✓ The safe, reliable, and low-pollutant combustion (thermal recycling) of the most complex fuels, waste materials, and reusable materials is what the rotary cup atomizer does best.
- ✓ Suitable for almost all heat generators and combustion chamber geometries.
- ✓ Robust, modular design based on 1,000-times proven rotary cup atomizer technology.
- ✓ Simultaneous combustion of several gases and oils.
- ✓ Very large control range for liquid and gaseous fuels.
- ✓ Low fuel supply pressure and low heat temperature required.
- ✓ High efficiency, low maintenance costs, and long life.
- ✓ Conforms to European directives and regulations of ship classification societies.
- ✓ Uncomplicated installation and commissioning.
- ✓ Unrivaled burner flexibility.
- ✓ Version for air preheating (optional).
- ✓ Integrated combustion management system (optional).
- ✓ Further modular system expansions possible.

Operating data

Burner size	Gas / ELFO in MW		Max. control range up to
	$\dot{Q}_{\min.}$	$\dot{Q}_{\max.}$	
18.03	0.45	1.7	1:5
25.03	0.57	2.3	1:5
35.03	0.57	3.4	1:8
50.03	0.68	4.5	1:8
70.02	0.74	5.7	1:8
100.01	1.10	7.3	1:8
100.03	1.10	9.1	1:10
140.02	1.40	11.5	1:10
140.03	1.80	14.0	1:10
200.02	1.80	17.0	1:10
280.01	2.10	20.4	1:10
280.02	2.30	24.0	1:10
280.03	2.90	28.3	1:10
400.02	3.50	33.9	1:10
400.03	4.10	39.6	1:10
560.03	4.70	45.3	1:10

COMBINING THE TRIED & TESTED WITH THE INNOVATIVE.

As the successor to the tried-and-tested SKVG and SKVJG burners, ROTONOX sets new standards in burner technology and brings tried-and-tested reliability to the next generation.

It satisfies all the requirements on future-proof and highly efficient combustion plants. In addition, its plug and play functionality allows it to be integrated in existing boiler applications with ease and ensures smooth commissioning.





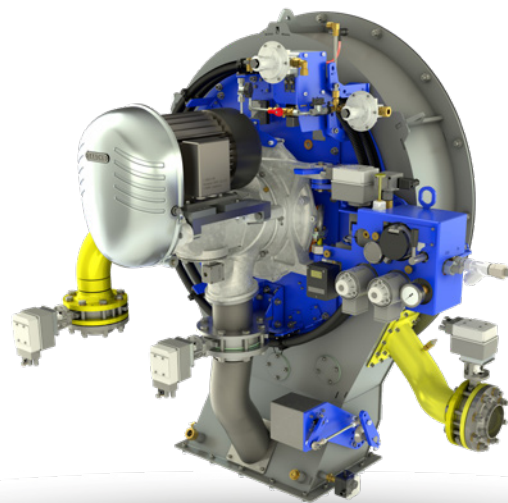
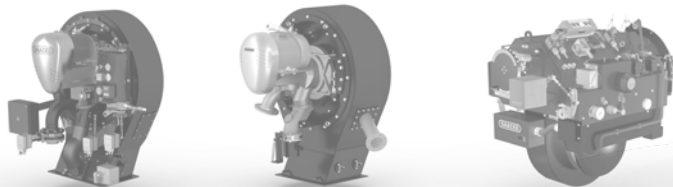



ROTONOX

The previous SKV product line



WHAT CHALLENGE DO YOU FACE?

A perfect fit for your industry

-  Energy and heat supply
-  Chemical industry
-  Refineries
-  Food industry
-  Waste recycling
-  Steel and metal processing
-  Building materials industry
-  Wood processing
-  Consumer goods



WE ARE THERE FOR YOU WHERE YOU NEED US.



Contact us:

SAACKE Combustion Services Limited

Langstone Park, Langstone Road
Havant, Hampshire, PO9 1SA

Tel. +44 (0) 2392 333 900

webenquiry@saacke.co.uk

WWW.SAACKE.COM