

**SAACKE**

# WITH SAACKE se@vis 4 YOU OPTIMIZE YOUR PLANT PERFORMANCE.

- ✓ Further developed
- ✓ Additional functions
- ✓ Future-proof

New  
version



# MANAGE YOUR PLANT SUCCESSFULLY WITH THE SAACKE se@vis 4.

---

Combustion plants need to operate safely and reliably. They should produce efficiently and flexibly, achieve maximum efficiency, and remain as **low-maintenance** as possible at the same time. As a user, you need to be in a position to react quickly. After all, **maximum availability** of the plant is essential for the success of your business.

The **SAACKE se@vis 4** intelligent management system is a real all-rounder, which has been further developed and features a wide range of additional functions. With just one system, you have your plant under control and available in an **efficient and future-proof** manner.

The SAACKE se@vis 4 control system impresses with its clear display and the ease of use of all relevant functions. **ONE** system for all our requirements. We are **100%** satisfied, not least thanks to the great reliability!

*Uwe Schliesser –  
Head of Operations Management CHP,  
Netzgesellschaft Düsseldorf mbH*



# THE ADVANTAGES FOR YOU AT A GLANCE.

---

- ✔ Control, regulation, and monitoring of combustion, boiler, and thermal processing plants.
- ✔ Simultaneous combustion of multiple fuels.
- ✔ Prioritization of the fuels by the user.
- ✔ Control of units such as feedwater pumps.
- ✔ 15 integrated and freely parametrizable controllers (e.g., PID, 3 components, etc.) for all plant functions such as: capacity, oxygen, furnace, feedwater, desalting, and vapor pressure controls.
- ✔ Premium safety combined with high speed and precision of the servodrives.
- ✔ Detailed initial value fault and operating messages.
- ✔ All relevant information in an overview.
- ✔ Touchscreen in different sizes for simple and intuitive operation, in multiple languages for use all over the world.
- ✔ Detailed process value history.
- ✔ Communication of all data with the control system possible.
- ✔ Operating, efficiency, and fault analysis via online portal (optional).
- ✔ Small and compact, the **SAACKE se@vis 4** takes up little space in the control cabinet.
- ✔ All components can be exchanged quickly without the need for a service technician or specialized personnel.
- ✔ Certified and type tested.

# EVERYTHING CONVENIENTLY UNDER CONTROL.

**Versatile, uncomplicated, and efficient:** The **SAACKE se@vis 4** modern combustion management system simplifies the control of your plant, allowing you to plan and deploy capacities effectively.

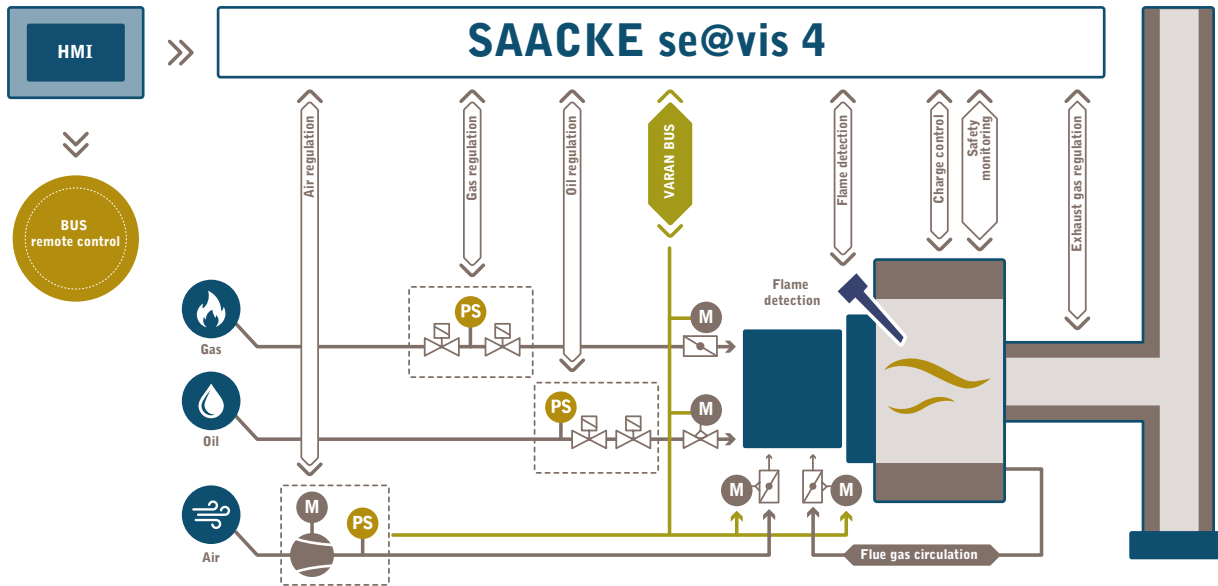

# THE STRUCTURE OF THE SYSTEM.

## The new SAACKE control system:

safe and reliable, flexibly expandable and future-proof.



### HMI operating device

5" or 10"



### BUS interface

Profibus DP, Profinet IO,  
Modbus TCP, Ethernet IP

Optional



### se@vis IO input and output expansion

32DI / 16RO, 12A / 4AO



### HMI for remote control

5" or 10"

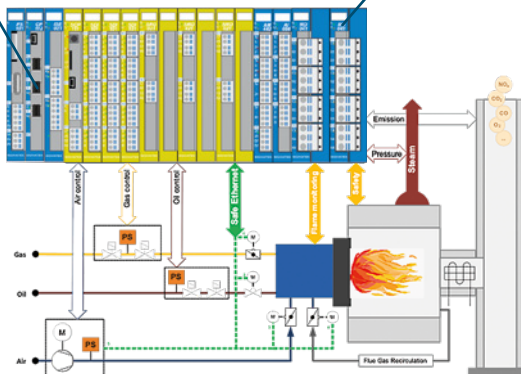

## Innovative drive concept

Up to 12 participants  
in an electrical network.



### Fail Safe Motor (FSM) 20C

6 to 15 Nm



### Fail Safe Motor (FSM) 25C

15 to 25 Nm



### Fail Safe Motor (FSM) 60C

25 bis 45 Nm



### Fail Safe Motor (FSM) 180C

80 to 140 Nm











### Fail Safe Motor 6000V for valve control

1,500 to 6,000 N

# WHAT CHALLENGE DO YOU FACE?

## A perfect fit for your industry

-  Energy and heat supply
-  Chemical industry
-  Refineries
-  Food industry
-  Waste recycling
-  Steel and metal processing
-  Building materials industry
-  Wood processing
-  Consumer goods

## Technical data

### se@vis 4

<b>Controllers</b>	15, freely configurable
<b>Input / output</b>	Analog and digital process values
<b>Interfaces</b>	Profibus DP, Profinet IO, Modbus TCP, Ethernet IP
<b>Number of network participants</b>	12 rapid and highly precise servodrives
<b>Operation</b>	Optionally via 5.7" or 10.4" touchscreen monitor

The **se@vis 4** combustion management system satisfies the requirements in accordance with DIN EN 298:2012-11, DIN EN 1643:2011-12, and DIN EN 12067-2:2004-06 taking into consideration prEN 12067-2:2020 and ISO 23552-1:2007-10 and is certified in accordance with the Pressure Equipment Directive 2014/68/EU and the Gas Appliances Regulation (EU) 2016/426. The safety-related, programmable I/O system of the **se@vis** SCU satisfies the requirements in accordance with EN ISO 13849 (PL e) and EN / IEC 62061 (SIL 3) and is certified in accordance with the Machinery Directive 2006/42/EC. The safety-related application software satisfies the requirements in accordance with DIN EN 62061:2016-05, Section 6.11.3 up to safety integrity level SIL 3. The safety-related position feedback of the **se@vis 4** FSM satisfies the requirements for use in electronic fuel/air ratio control (ERC) systems in accordance with DIN EN 12067-2:2004-06 taking into consideration prEN 12067-2:2020 and ISO 23552-1:2007-10 and can be used up to performance level PL e in accordance with DIN EN ISO 13849-1. The **se@vis 4** combustion management system satisfies the requirements of DIN EN 50156-2 as well as, with regard to the shutdown of the entire fuel supply of combustion plants in continuous operation, the requirements of DIN EN 50156-1, Section 10.5.5 for safety functions up to safety integrity level SIL 3. The **se@vis 4** combustion management system satisfies the functional requirements of DIN EN 267, ISO 22967, DIN EN 676, ISO 22968, DIN EN 12952-8, DIN EN 12953-7, DIN EN 746-2, and ISO 13577-2.

# WE ARE THERE FOR YOU IN THE EVENT OF A FAULT.

---

With the **SAACKE se@vis 4**, you can work more independently and effectively in the event of a fault. You receive an automatic warning notification and can access your plant **remotely** from anywhere in the world. Or you can let us take care of things for you.

Our experienced engineers respond to error messages and work together with you to improve the efficiency or **reduce the fuel consumption**. SAACKE identifies potential failures in advance and alerts you in plenty of time, making predictive maintenance possible.

If you so wish, you can also grant SAACKE secured remote access to your systems. Many faults can be resolved remotely via instructions – that translates to lower maintenance efforts, saving money and increasing the availability of your plant.



# WE ARE THERE FOR YOU WHERE YOU NEED US.

---



**Contact us:**

**SAACKE Combustion Services Limited**

Langstone Park, Langstone Road  
Havant, Hampshire, PO9 1SA

Tel. +44 (0) 2392 333 900  
webenquiry@saacke.co.uk

[WWW.SAACKE.COM](http://WWW.SAACKE.COM)